

INSTALLATION INSTRUCTIONS

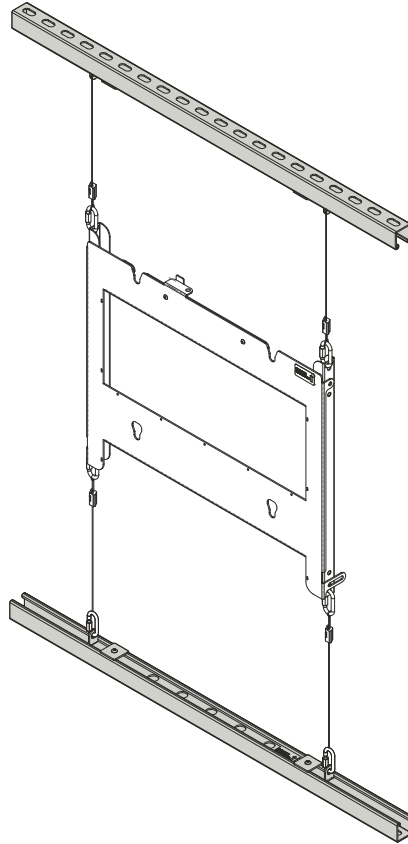

Lateral Shift Accessory

 **CHIEF**[®]

A brand of  **legrand**[®]

PACFCL

DISCLAIMER

Legrand | AV and its affiliated corporations and subsidiaries (collectively "Legrand | AV"), intend to make this manual accurate and complete. However, Legrand | AV makes no claim that the information contained herein covers all details, conditions or variations, nor does it provide for every possible contingency in connection with the installation or use of this product. The information contained in this document is subject to change without notice or obligation of any kind. Legrand | AV makes no representation of warranty, expressed or implied, regarding the information contained herein. Legrand | AV assumes no responsibility for accuracy, completeness or sufficiency of the information contained in this document.

Chief® is a registered trademark of Legrand AV Inc.

DEFINITIONS

MOUNTING SYSTEM: A MOUNTING SYSTEM is the primary Chief product to which an accessory and/or component is attached.

ACCESSORY: AN ACCESSORY is the secondary Chief product which is attached to a primary Chief product, and may have a component attached or setting on it.

COMPONENT: A COMPONENT is an audiovisual item designed to be attached or resting on an accessory or mounting system such as a video camera, CPU, screen, display, projector, etc.

WARNING: A WARNING alerts you to the possibility of serious injury or death if you do not follow the instructions.

CAUTION: A CAUTION alerts you to the possibility of damage or destruction of equipment if you do not follow the corresponding instructions.

IMPORTANT SAFETY INSTRUCTIONS

WARNING: Failure to read, thoroughly understand, and follow all instructions can result in serious personal injury,

damage to equipment, or voiding of factory warranty! It is the installer's responsibility to make sure all accessories are properly assembled and installed using the instructions provided.

WARNING: Failure to provide adequate structural strength for this accessory can result in serious personal injury or damage to equipment! It is the installer's responsibility to make sure the structure to which this accessory is attached can support five times the combined weight of all equipment. Reinforce the structure as required before installing the accessory.

WARNING: Exceeding the weight capacity can result in serious personal injury or damage to equipment! It is the installer's responsibility to make sure the combined weight of all components attached to the FSC1U mounting system combined with the PACFCL does not exceed a total of 130 lbs (58.9 kg) or 65 lbs (29.5 kg) per display if using with PACFCB back-to-back accessory.

WARNING: Use this accessory only for its intended use as described in these instructions. Do not use attachments not recommended by the manufacturer.

WARNING: Never operate this accessory if it is damaged. Return the accessory to a service center for examination and repair.

WARNING: Do not use this accessory outdoors.

IMPORTANT ! : The FCS1U mounting system is designed to be mounted to a:

- Structurally sound solid concrete surface with a minimum thickness of 4" (101.6mm) or greater; or
- wood surface that measures at least 3-1/2" x 1-1/2" (88.9mm x 38.1mm)

--SAVE THESE INSTRUCTIONS--

DIMENSIONS

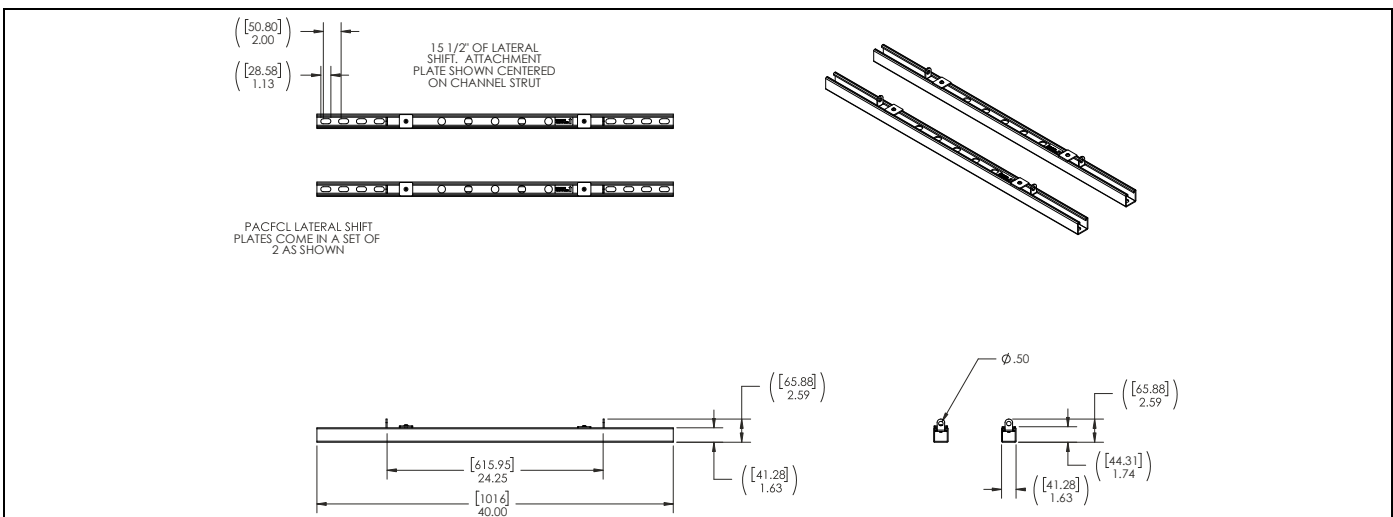

TOOLS/PARTS REQUIRED FOR INSTALLATION

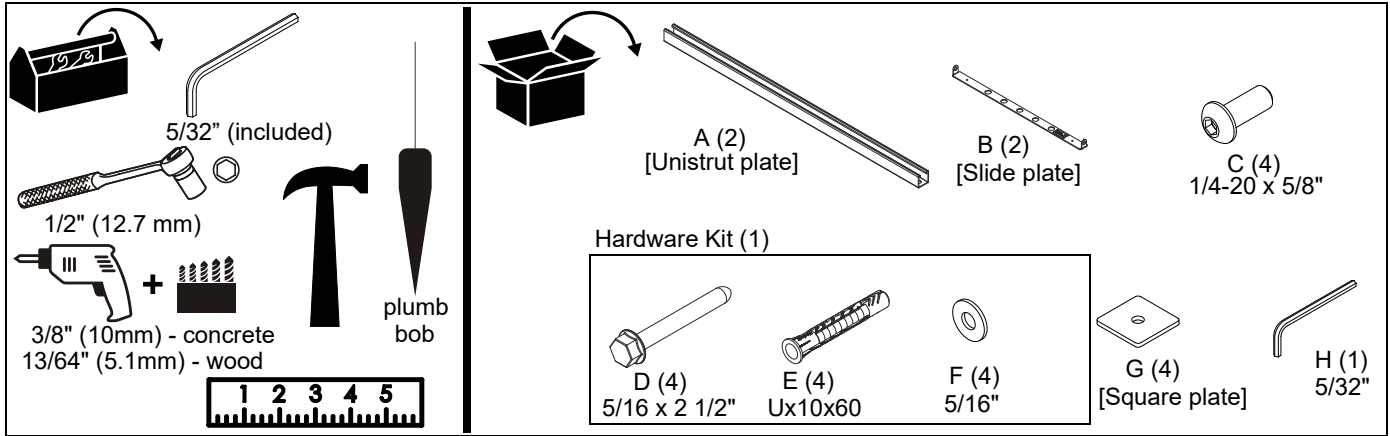

Assembly And Installation

Connecting to Floor/Ceiling

1. Determine mounting location taking into consideration screen size and any possible obstructions.
2. Mark locations for two mounting holes in ceiling using unistrut plate as a template. Any two holes on unistrut may be used as long as they are not located on the same half of the unistrut.
3. Drill two 3/8" (concrete) or 13/64" (wood) pilot holes at marked locations. (See Figure 1)
4. (Concrete only) Install two Ux10x60 anchors (E) into drilled holes. (See Figure 1)
5. Install two 5/16 x 2 1/2" hex head carriage screws (D) through 5/16" washers (F) and into drilled holes or anchors (E) to secure unistrut plate (A) to ceiling. (See Figure 1)

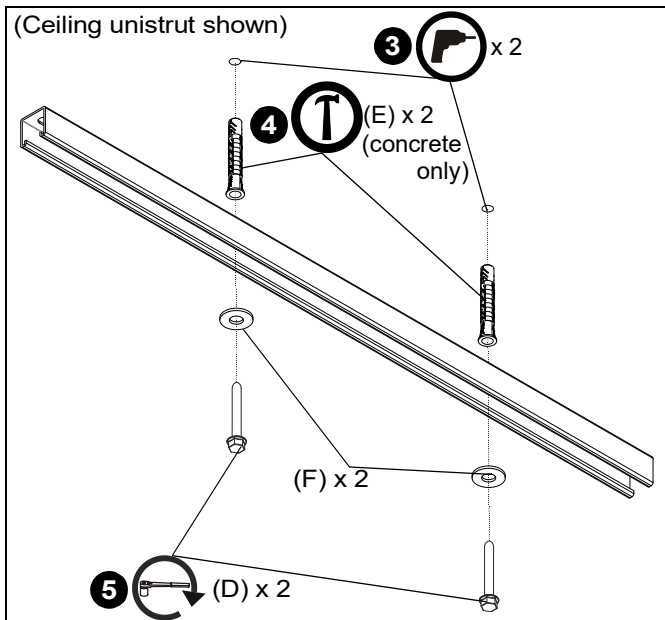

Figure 1

6. Repeat Steps 1-5 at corresponding location on the floor and directly underneath installed unistrut using a plumb bob tool to determine mounting hole locations.

Connecting FCS1U to Unistruts

1. Insert slide plate (B) into unistrut plate (A). (See Figure 2)

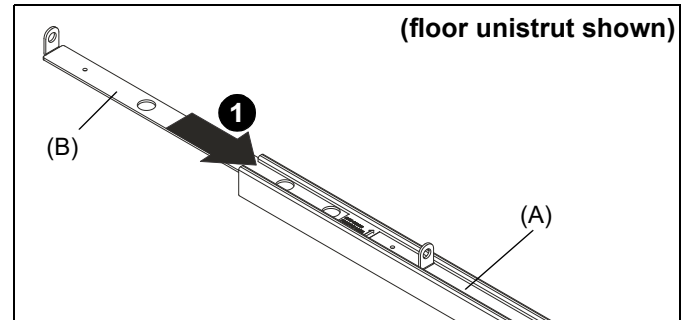

Figure 2

2. Use two 1/4-20 x 5/8" button head cap screws (C) to attach square plates (G) to slide plate (B). (See Figure 3)

NOTE: Screws (C) only need to be tightened to lock in position.

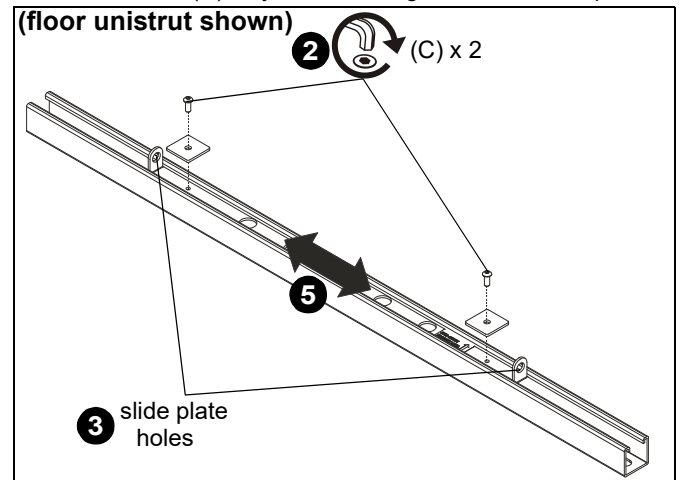

Figure 3

3. Repeat Steps 1-2 for floor unistrut.
4. Attach FCS1U cables to slide plate holes using connecting links or turnbuckles as shown in FCS1U installation instructions.

Adjustments

5. Adjust position laterally as desired. (See Figure 3)



A brand of  **legrand**

8800-003133 Rev01
©2019 Legrand | AV
www.legrandav.com
05/19

USA/International	A 6436 City West Parkway, Eden Prairie, MN 55344 P 800.582.6480 / 952.225.6000 F 877.894.6918 / 952.894.6918
Europe	A Franklinstraat 14, 6003 DK Weert, Netherlands P +31 (0) 495 580 852 F +31 (0) 495 580 845
Asia Pacific	A Office No. 918 on 9/F, Shatin Galleria 18-24 Shan Mei Street Fotan, Shatin, Hong Kong P 852 2145 4099 F 852 2145 4477

