

INSTALLATION INSTRUCTIONS

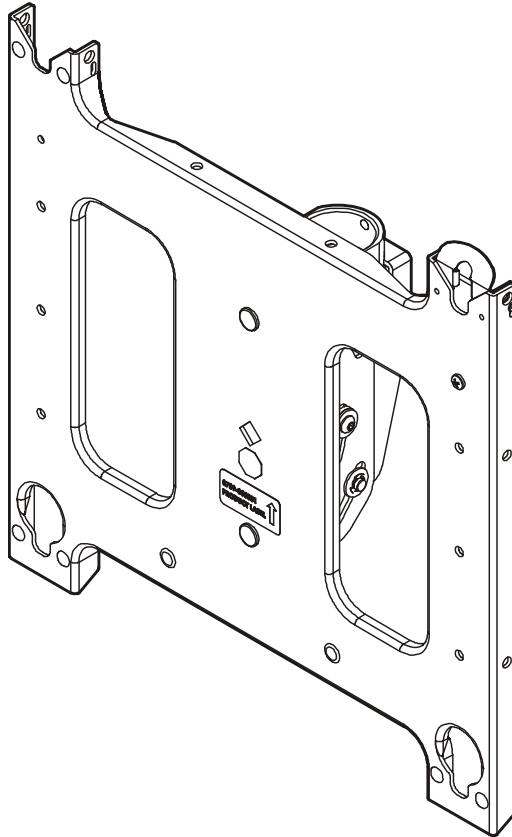

Single Ceiling Mount

DISCLAIMER

Milestone AV Technologies and its affiliated corporations and subsidiaries (collectively "Milestone"), intend to make this manual accurate and complete. However, Milestone makes no claim that the information contained herein covers all details, conditions or variations, nor does it provide for every possible contingency in connection with the installation or use of this product. The information contained in this document is subject to change without notice or obligation of any kind. Milestone makes no representation of warranty, expressed or implied, regarding the information contained herein. Milestone assumes no responsibility for accuracy, completeness or sufficiency of the information contained in this document.

Chief® and ClickConnect™ are registered trademarks of Milestone AV Technologies. All rights reserved.



WARNING: Use this mounting system only for its intended use as described in these instructions. Do not use attachments not recommended by the manufacturer.



WARNING: Never operate this mounting system if it is damaged. Return the mounting system to a service center for examination and repair.



WARNING: Do not use this product outdoors.

--SAVE THESE INSTRUCTIONS--



IMPORTANT SAFETY INSTRUCTIONS



WARNING: A WARNING alerts you to the possibility of serious injury or death if you do not follow the instructions.



CAUTION: A CAUTION alerts you to the possibility of damage or destruction of equipment if you do not follow the corresponding instructions.



WARNING: Failure to read, thoroughly understand, and follow all instructions can result in serious personal injury, damage to equipment, or voiding of factory warranty! It is the installer's responsibility to make sure all components are properly assembled and installed using the instructions provided.



WARNING: Failure to provide adequate structural strength for this component can result in serious personal injury or damage to equipment! It is the installer's responsibility to make sure the structure to which this component is attached can support five times the combined weight of all equipment. Reinforce the structure as required before installing the component.



WARNING: Exceeding the weight capacity can result in serious personal injury or damage to equipment! It is the installer's responsibility to make sure the combined weight of all components located between the supporting structure and the mount does not exceed 200 lbs (90.7 kg).

- The weight capacity of the mount may be LIMITED to the lowest capacity of any other component located between the mount and the supporting structure!

DIMENSIONS

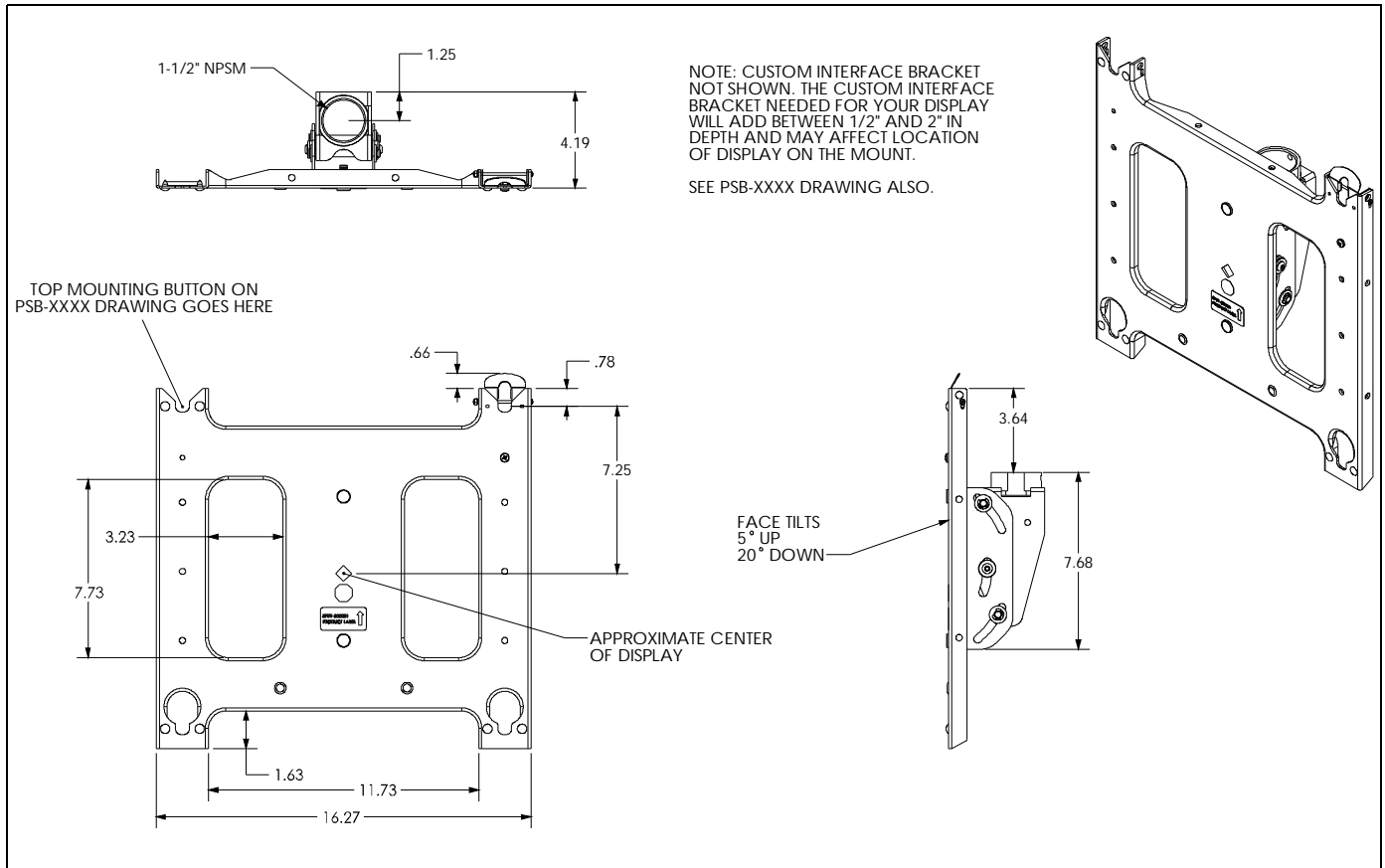

LEGEND

	Tighten Fastener		Open-Ended Wrench
	Apretar elemento de fijación		Llave de boca
	Befestigungsteil festziehen		Gabelschlüssel
	Apertar fixador		Chave de bocas
	Serrare il fissaggio		Chiave a punte aperte
	Bevestiging vastdraaien		Steeksleutel
Serrez les fixations	Clé à fourche		
	Loosen Fastener		Hex-Head Wrench
	Aflojar elemento de fijación		Llave de cabeza hexagonal
	Befestigungsteil lösen		Sechskantschlüssel
	Desapertar fixador		Chave de cabeça sextavada
	Allentare il fissaggio		Chiave esagonale
	Bevestiging losdraaien		Zeskantsleutel
Desserrez les fixations	Clé à tête hexagonale		

TOOLS REQUIRED FOR INSTALLATION

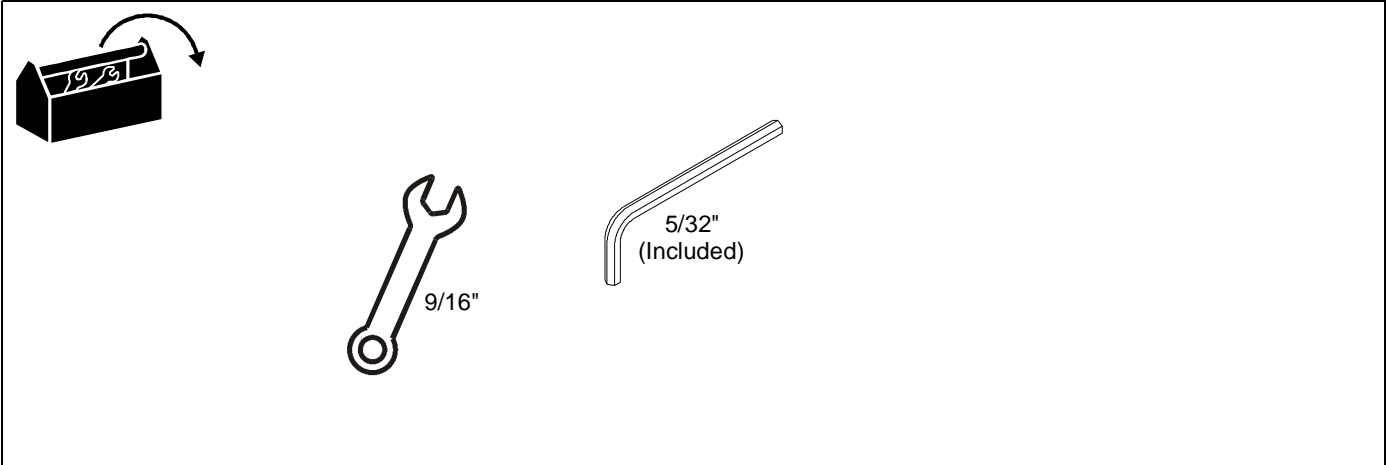

PARTS

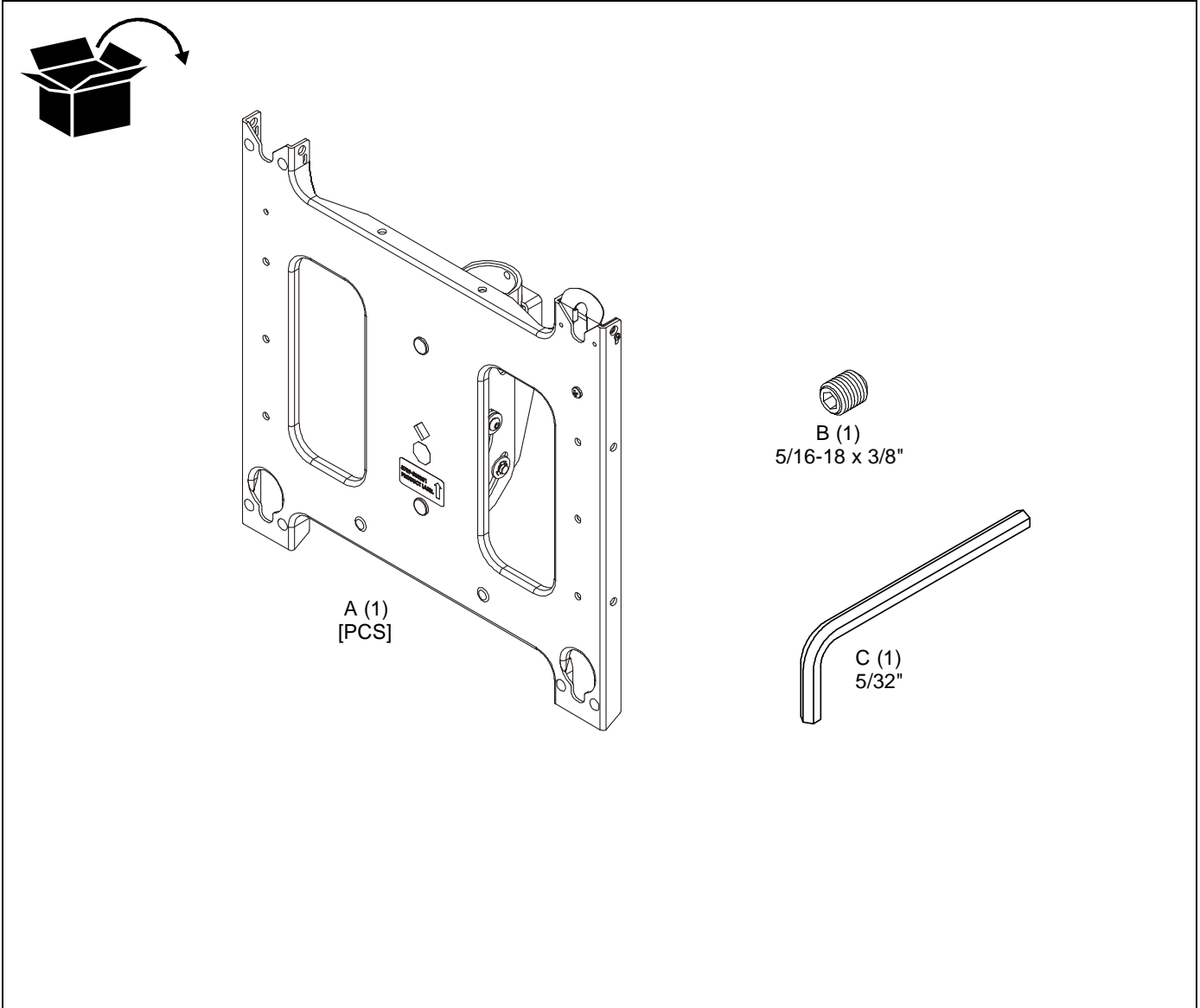

INSTALLATION



WARNING: FAILURE TO PROVIDE ADEQUATE STRUCTURAL STRENGTH FOR THIS COMPONENT CAN RESULT IN SERIOUS PERSONAL INJURY OR DAMAGE TO EQUIPMENT! It is the installer's responsibility to make sure the structure to which this component is attached can support five times the combined weight of all equipment. Reinforce the structure as required before installing the component.

IMPORTANT ! : These installation instructions assume that a 1-1/2" NPT or NPSM (Schedule 40, 0.154" minimum thickness aluminum - ASTM B221) pipe (not included) has been properly installed and is in place.

Attaching Mount to NPT Pipe



CAUTION: Watch for pinch points. Do not place fingers between moveable parts.

1. Thread the PCS mount (A) onto the existing 1-1/2" NPT or NPSM pipe (not included) until tight. (See Figure 1)
2. Install and tighten the 5/16-18 x 3/8" set screw (B) using the 5/32" hex head wrench (C). (See Figure 1)

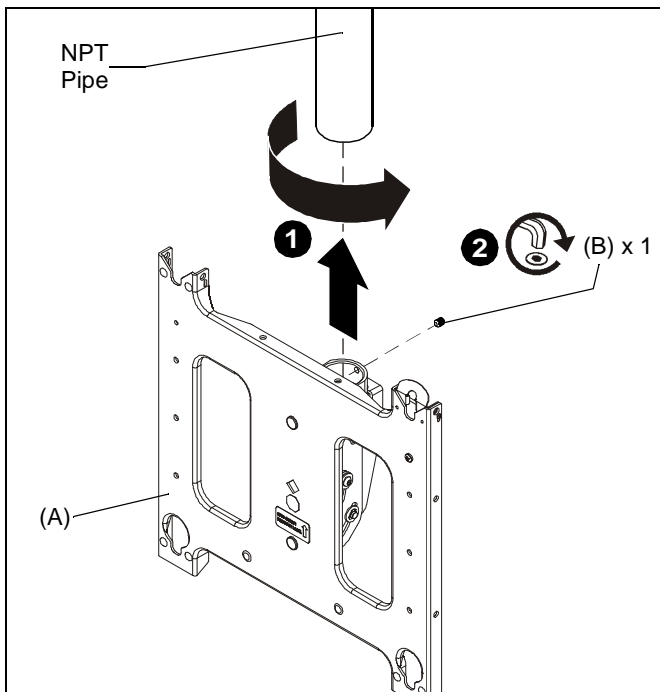

Figure 1

Attaching Interface Bracket to Display

1. Attach interface bracket to display following instructions included with interface bracket kit.

Attaching Displays to Mount

1. While supporting both sides of display, align four mounting buttons on display or interface bracket with four mounting holes in mount. (See Figures 2, 3 and 4)

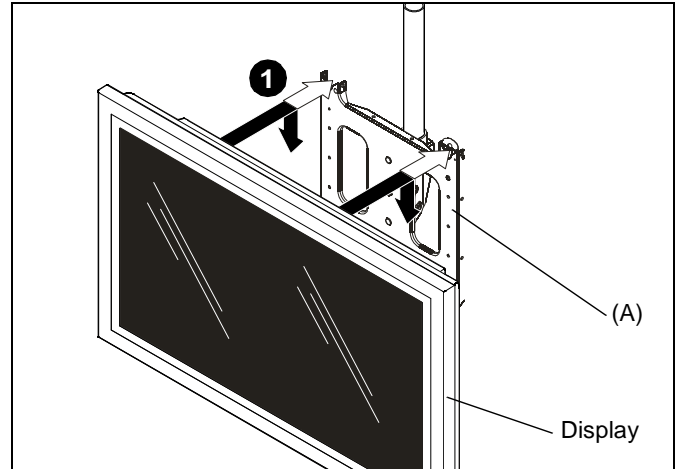

Figure 2



WARNING: DISPLAY MAY WEIGH IN EXCESS OF 40 LBS! Always use two people and proper lifting techniques when installing or positioning display on mount.

2. Lower display into place listening for audible "click" to ensure recessed area of mounting buttons are properly seated in lower area of mounting holes and ClickConnect mechanism has engaged. (See Fig. 2, 3 and 4)

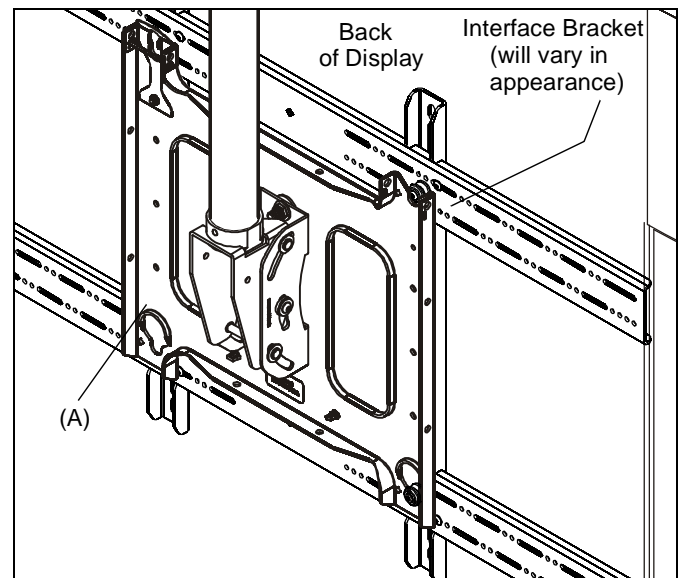

Figure 3



WARNING: IMPROPER INSTALLATION CAN LEAD TO DISPLAY FALLING CAUSING SERIOUS PERSONAL INJURY OR DAMAGE TO EQUIPMENT! Ensure mounting buttons are completely engaged in mounting holes.

Holes are provided in the faceplate for use with a padlock or similar locking device, if desired. In addition, the pin and nut may be removed from the upper holes and moved to the lower holes for use as a more permanent locking device. (See Figure 4).

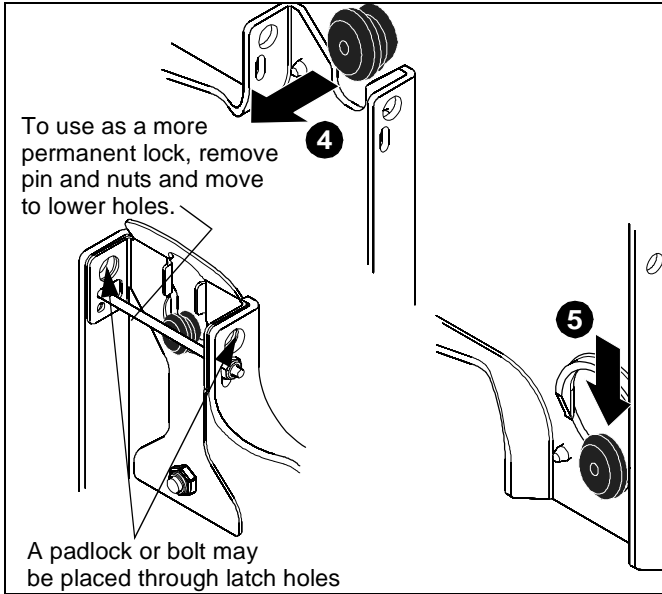

Figure 4

Removing Display

1. Disconnect all power/audio/video cables.
2. Remove bolt or padlock from faceplate (if used). (See Figure 5)

NOTE: The pin may have been used as a more permanent locking device. If so, remove nut and pin and move from the lower holes to the upper holes.

3. Pull back on flag on upper mounting hole and press pin down into "Open" position. (See Figure 5)



WARNING: THE DISPLAY MAY WEIGH IN EXCESS OF 40 LBS EACH! Always use two people and proper lifting techniques when installing or positioning display.

4. Carefully lift display from mount.
5. Lift up on pin and place flag back against faceplate to return it to "Closed" position. (See Figure 5)

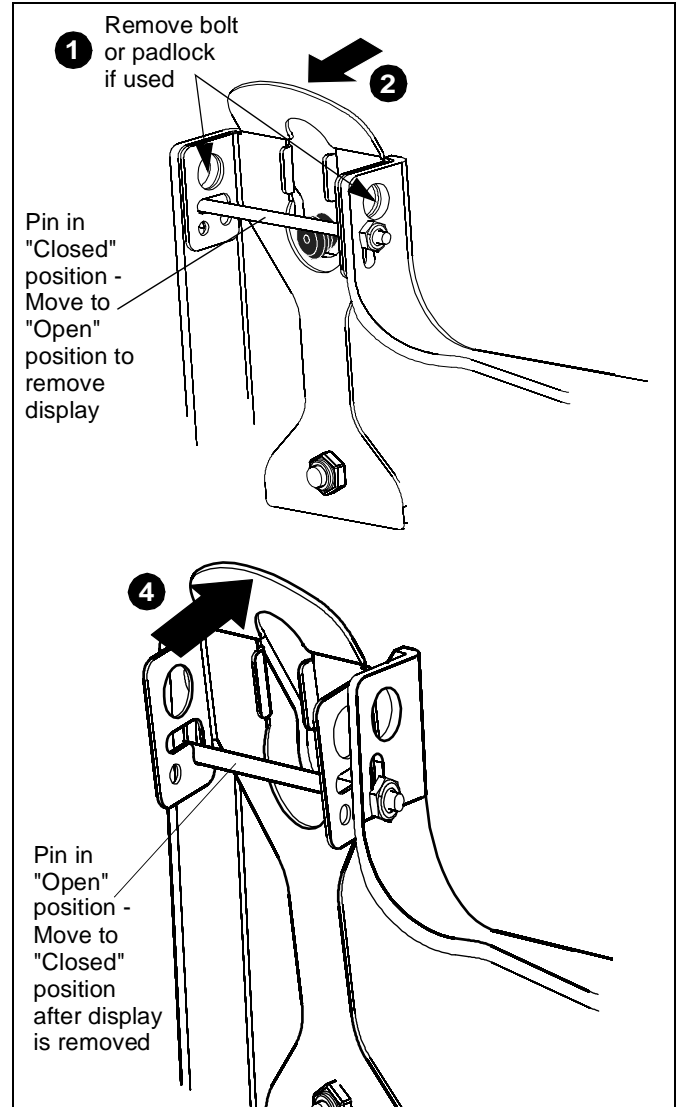

Figure 5

Adjusting Display



CAUTION: Watch for pinch points. Do not place fingers between moveable parts.

Adjusting Roll

1. Using a 9/16" wrench, loosen the Nylock roll adjustment nut on back of mounting plate. (See Figure)
2. Tilt the faceplate left or right as required.
3. Tighten nut.

NOTE: Do NOT overtighten fasteners.

Adjusting Pitch

1. Adjust display to the desired pitch.
2. Using the 5/32" hex head wrench (C), tighten the pitch adjustment screw to hold mount in position. (See Figure)

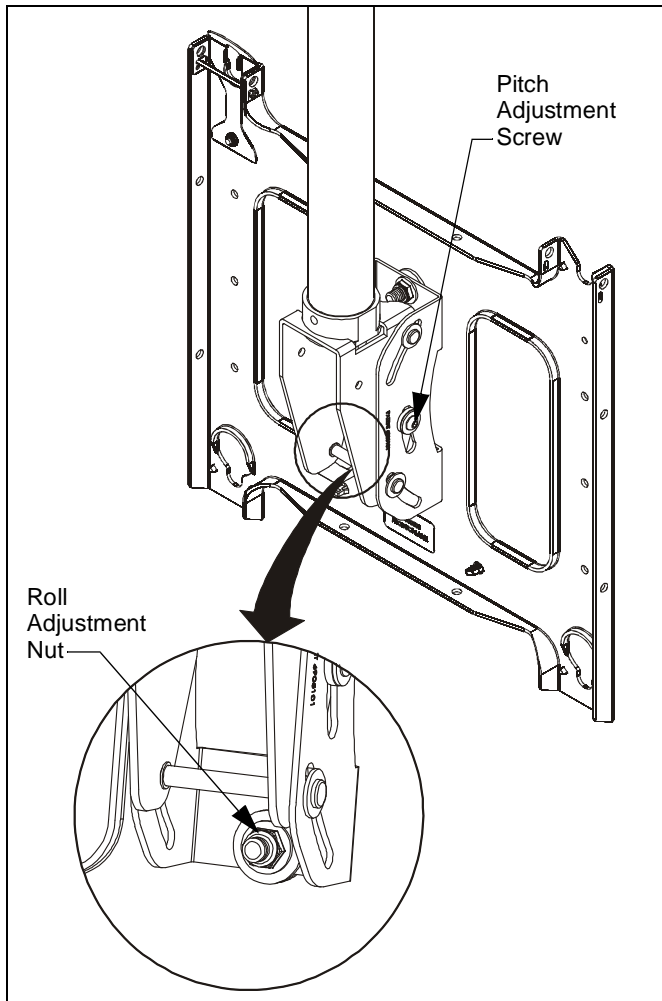

Figure 6



Our Mounts. **Your Vision.**

Chief Manufacturing, a products division
of Milestone AV Technologies

8800-002111 Rev00
©2011 Milestone AV Technologies, a
Duchossois Group Company
www.chiefmfg.com
11/11

USA/International	A 8401 Eagle Creek Parkway, Savage, MN 55378 P 800.582.6480 / 952.894.6280 F 877.894.6918 / 952.894.6918
Europe	A Franklinstraat 14, 6003 DK Weert, Netherlands P +31 (0) 495 580 852 F +31 (0) 495 580 845
Asia Pacific	A Office No. 1 on 12/F, Shatin Galleria 18-24 Shan Mei Street Fotan, Shatin, Hong Kong P 852 2145 4099 F 852 2145 4477



INSTALLATION INSTRUCTIONS

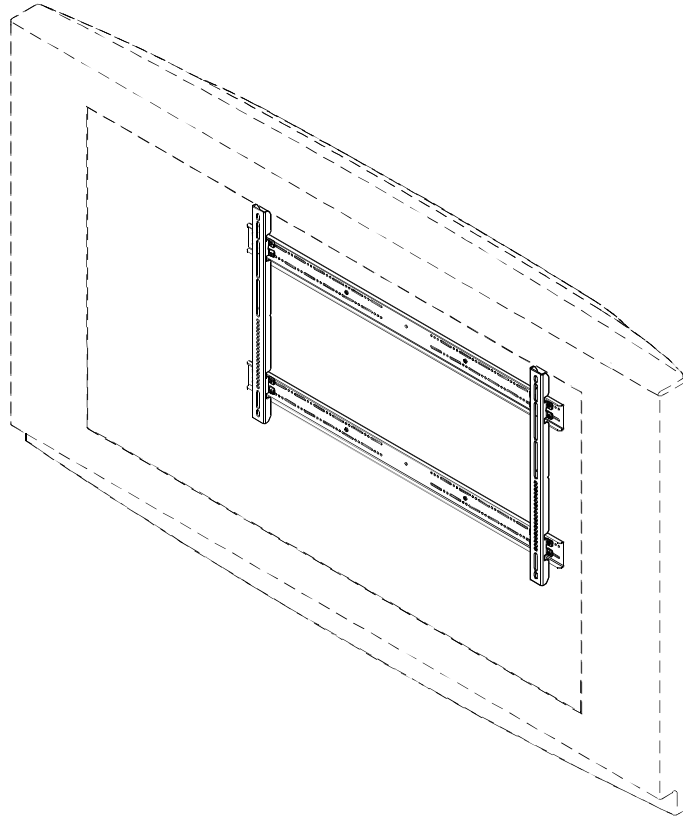

Universal Plasma Interface Bracket

DISCLAIMER

Milestone AV Technologies, and its affiliated corporations and subsidiaries (collectively, "Milestone"), intend to make this manual accurate and complete. However, Milestone makes no claim that the information contained herein covers all details, conditions or variations, nor does it provide for every possible contingency in connection with the installation or use of this product. The information contained in this document is subject to change without notice or obligation of any kind. Milestone makes no representation of warranty, expressed or implied, regarding the information contained herein. Milestone assumes no responsibility for accuracy, completeness or sufficiency of the information contained in this document.

®Chief is a registered trademark of Milestone AV Technologies. All rights reserved.



IMPORTANT WARNINGS AND CAUTIONS!



WARNING: A WARNING alerts you to the possibility of serious injury or death if you do not follow the instructions.



CAUTION: A CAUTION alerts you to the possibility of damage or destruction of equipment if you do not follow the corresponding instructions.



WARNING: Failure to read, thoroughly understand, and follow all instructions can result in serious personal injury, damage to equipment, or voiding of factory warranty! It is the installer's responsibility to make sure all components are properly assembled and installed using the instructions provided.



WARNING: Failure to provide adequate structural strength for this component can result in serious personal injury or damage to equipment! It is the installer's responsibility to make sure the structure to which this component is attached can support five times the combined weight of all equipment. Reinforce the structure as required before installing the component.



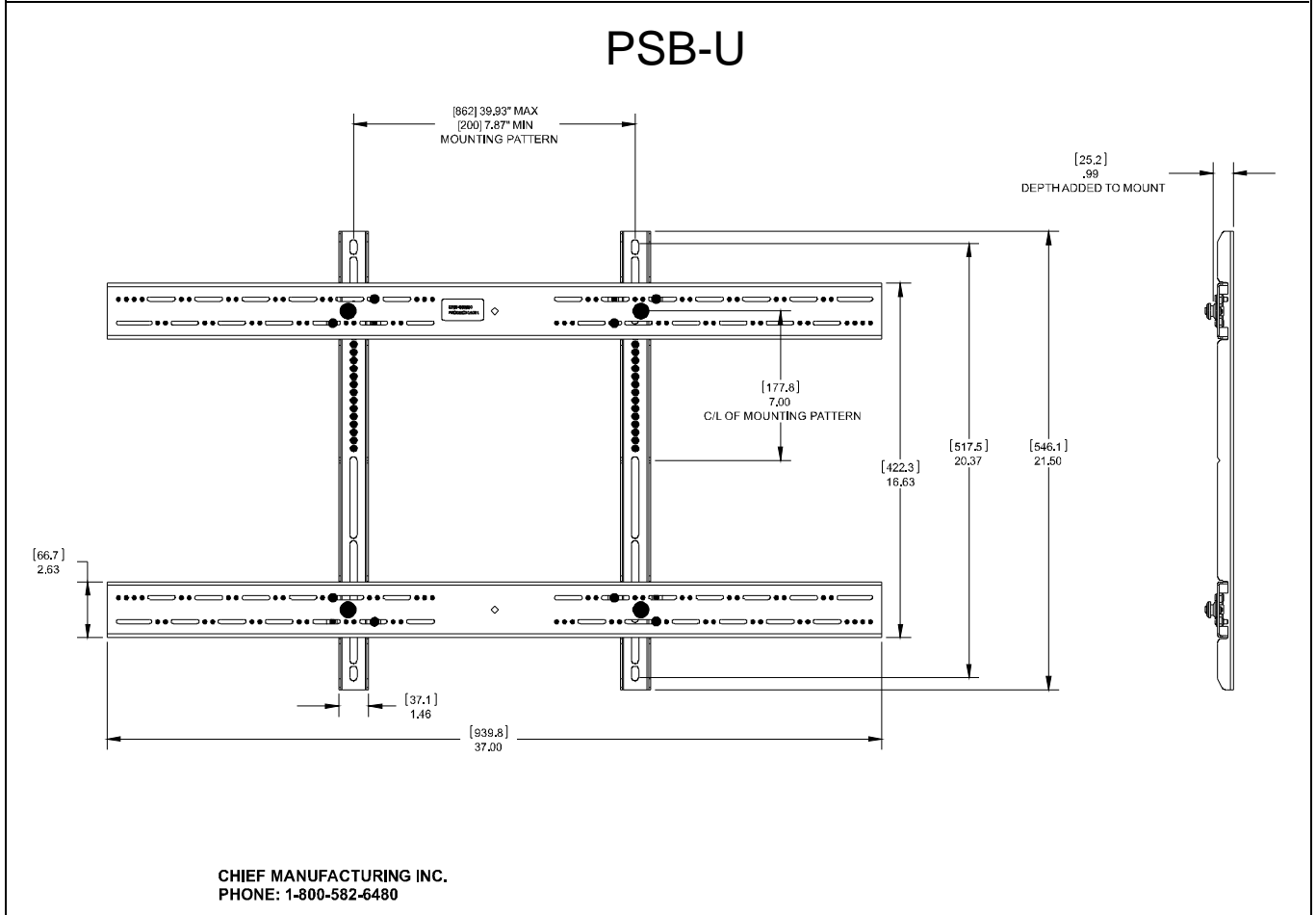
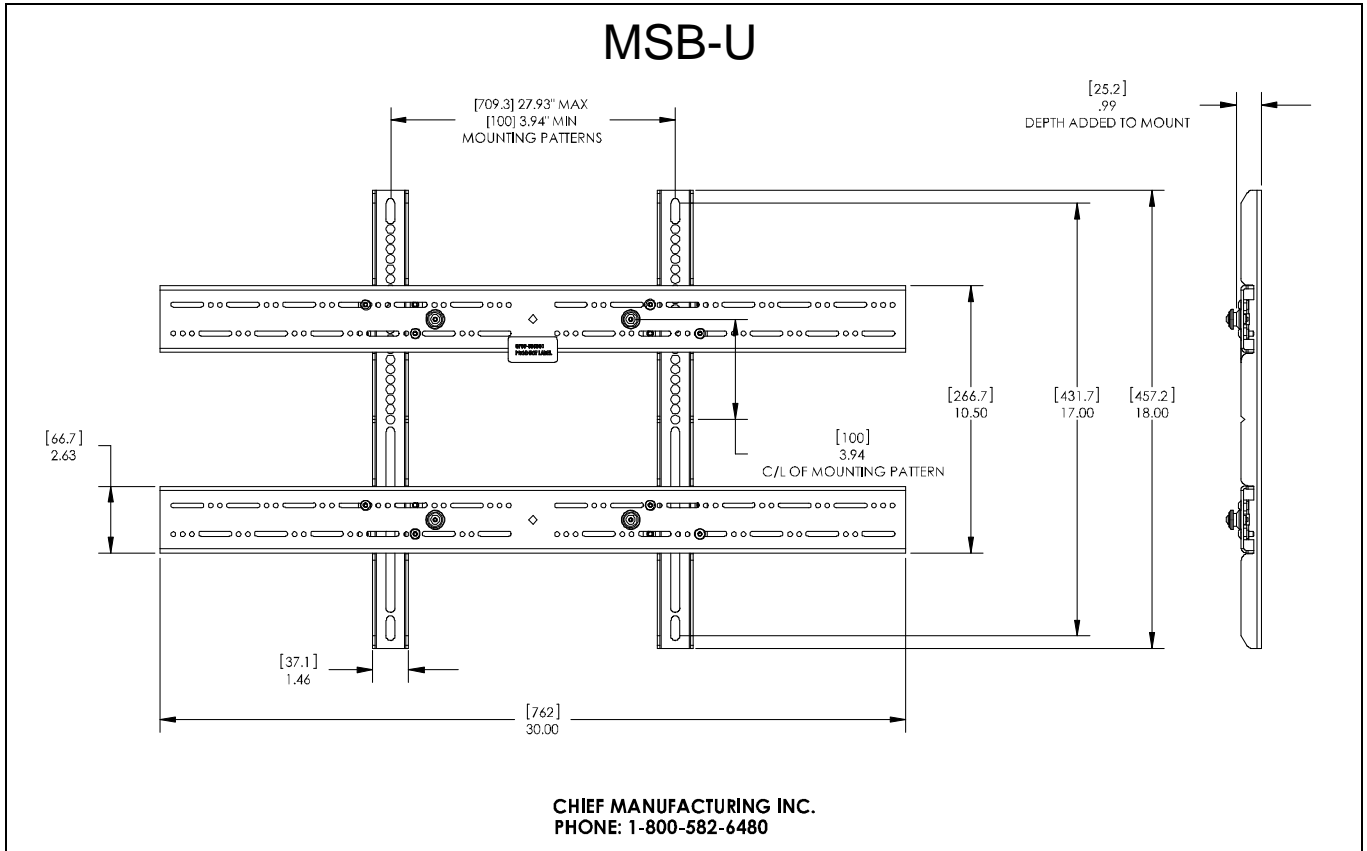

WARNING: Exceeding the weight capacity of the Listed mount can result in serious personal injury or damage to equipment! The MSBU/PSBU is used with several Listed flat panel mounts that have maximum weight ratings from 125 lb (56.7 kg) for the MSBU to 200 lb (90.7 kg) for the PSBU.

NOTE: The Listed Mount installation instructions will identify Model MSBU or PSBU interface brackets, and will specify the weight rating of the mount.



LEGEND

	Tighten Fastener
	Apretar elemento de fijación
	Befestigungsteil festziehen
	Apertar fixador
	Serrare il fissaggio
	Bevestiging vastdraaien
	Serrez les fixations
Сожмите Застежку	

	Phillips Screwdriver
	Destornillador Phillips
	Kreuzschlitzschraubendreher
	Chave de fendas Phillips
	Cacciavite a stella
	Kruiskopschroevendraaier
	Tournevis à pointe cruciforme
Отвертка	

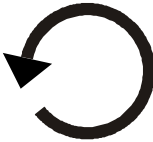
	Loosen Fastener
	Aflojar elemento de fijación
	Befestigungsteil lösen
	Desapertar fixador
	Allentare il fissaggio
	Bevestiging losdraaien
	Desserrez les fixations
Ослабьте Застежку	

	Hex-Head Wrench
	Llave de cabeza hexagonal
	Sechskantschlüssel
	Chave de cabeça sextavada
	Chiave esagonale
	Zeskantsleutel
	Clé à tête hexagonale
Ключ с шестигранной головкой	

TOOLS REQUIRED FOR INSTALLATION AND PARTS

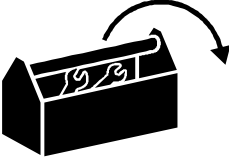



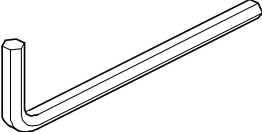





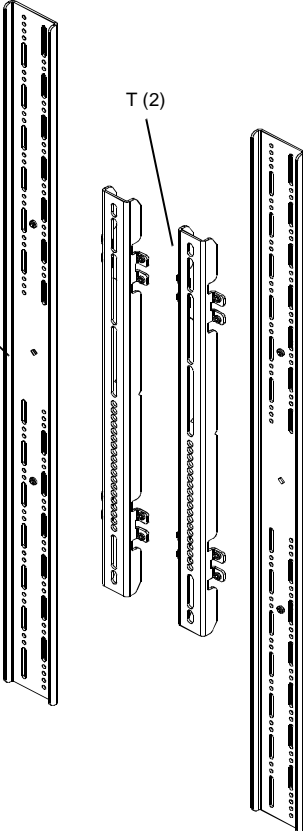















1/8" (provided)





S (2)

T (2)

<p>A (8) (Bag A) #10-24 x 1/2" </p> <p>B (6) (Bag B) M8 x 16mm </p> <p>C (6) (Bag C) M8 x 20mm </p> <p>D (6) (Bag D) M8 x 35mm </p> <p>E (8) (Bag E) M6 x 16mm </p> <p>F (8) (Bag F) M6 x 20mm </p> <p>G (8) (Bag G) M6 x 35mm </p> <p>S (4) (Bag Q) M8 x 60mm </p>	<p>H (8) (Bag H) M5 x 16mm </p> <p>I (8) (Bag I) M5 x 25mm </p> <p>J (8) (Bag J) M5 x 40mm </p> <p>K (8) (Bag K) M4 x 16mm </p> <p>L (8) (Bag L) M4 x 25mm </p> <p>M (8) (Bag M) M4 x 40mm </p>	<p>N (8) (Bag N) .750" x .250" </p> <p>O(8) (Bag O) 20mm </p> <p>P(8) (Bag P) #10 </p> <p>Q(8) (Bag P) .318" x .078" </p> <p>R(8) (Bag P) .250" </p>
---	---	---

INSTALLATION



WARNING: IMPROPER INSTALLATION CAN LEAD TO MOUNT FALLING CAUSING SERIOUS PERSONAL INJURY OR DAMAGE TO EQUIPMENT! DO NOT substitute hardware. Only use hardware provided or specified by manufacturer.

1. Determine and mark the vertical center position between the Left side Upper and Lower mounting holes in display. (See Figure 1)
2. Determine and mark the vertical center position between the Right side Upper and Lower mounting holes in display. (See Figure 1)
3. Orient vertical mounting bracket (T) so that mounting holes are on top and mounting slots are on bottom. (See Figure 1)
4. Align mounting holes in vertical mounting bracket (T) with upper and lower mounting holes in display.
5. Adjust vertical mounting bracket (T) position until mark made in step 1 aligns with center mark in vertical mounting bracket (T).
6. Secure Left side vertical mounting bracket (T) to display using two flat washer (R), and Phillips pan head screws (B through M). (See Figure 2)

NOTE: If the display has a recessed mounting surface, protrusions or a power box, a spacer and longer mounting hardware must be placed between the display and vertical mounting bracket (T). (See Figure 2)

7. Repeat steps 3 through 6 for Right side vertical mounting bracket using the same hole locations to align brackets horizontally.

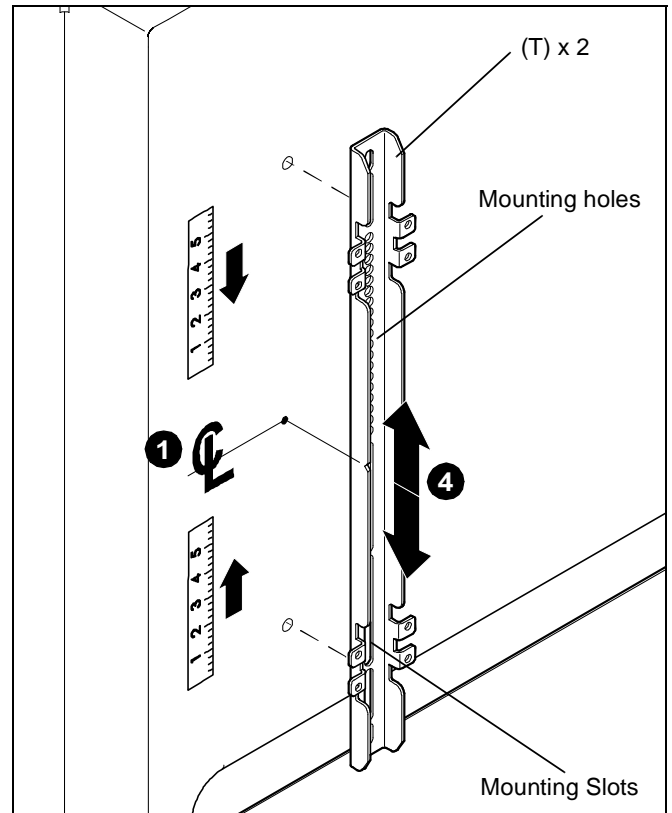

Figure 1

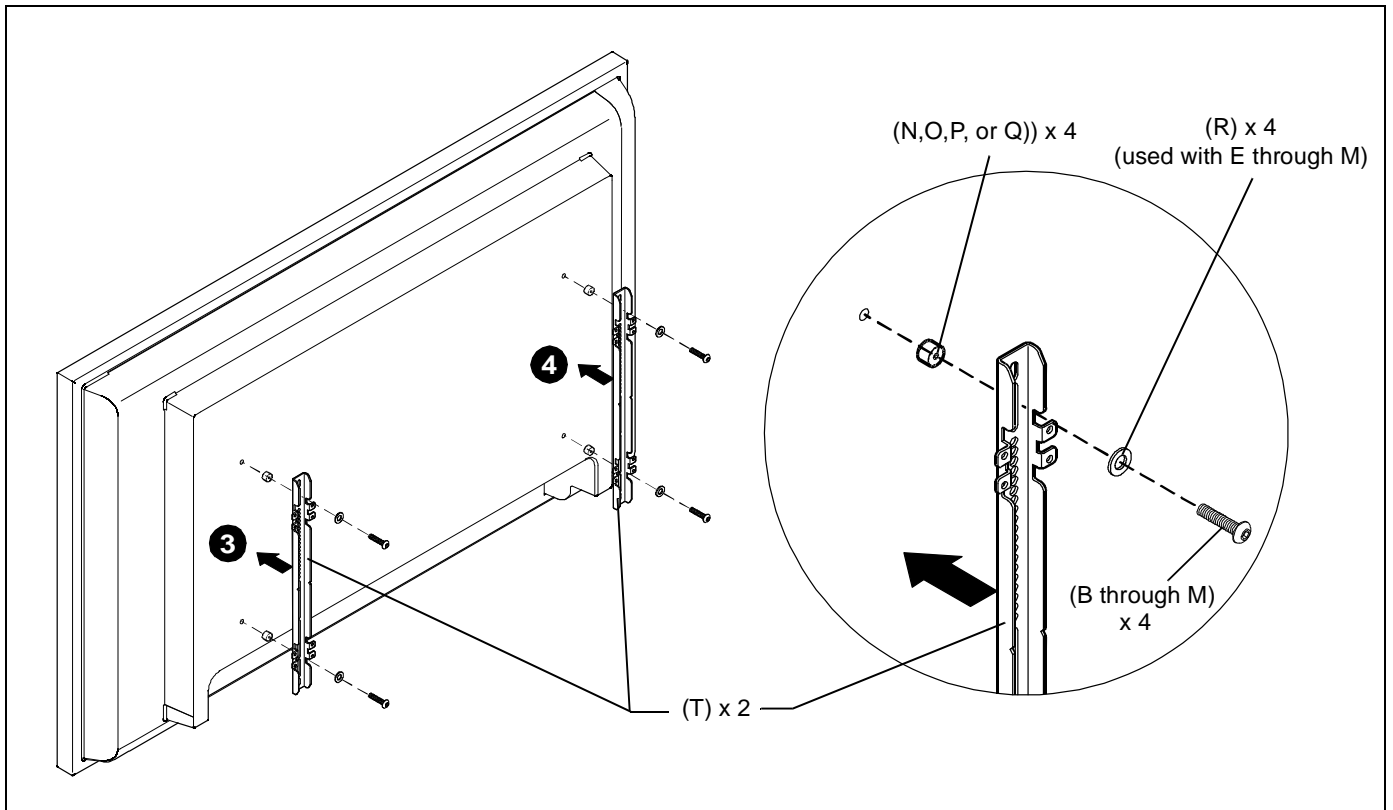

Figure 2

8. Determine and mark the horizontal center position between the Left and Right *TOP* mounting holes in display. (See Figure 3)
9. Determine and mark the horizontal center position between the Left and Right *BOTTOM* mounting holes in display. (See Figure 3)
10. Orient upper horizontal mounting bracket (S) so that flanges are facing towards display and resting in recessed area of left and right vertical mounting brackets (T). (See Figure 1)
11. Adjust Upper horizontal mounting bracket (S) position until center diamond in horizontal mounting bracket (S) aligns with mark made in step 8 and mounting holes and slots horizontal mounting bracket (S) are aligned with threaded holes in mounting tabs of left and right vertical mounting brackets (T). (See Figure 3) and (See Figure 4)
12. Secure upper horizontal mounting bracket (S) to left and right vertical mounting brackets (T) using four Button head cap screws (A). (See Figure 4)
13. Repeat steps 10 through 12 for lower horizontal mounting bracket (S).

IMPORTANT ! : The orientation of, and mounting holes used, when installing the lower horizontal mounting bracket must be the same as the upper horizontal mounting bracket. Vertically align upper and lower brackets by aligning holes or end of slots. (See Figure 4)

IMPORTANT ! : Whenever possible install mounting screws diagonally as shown in detail in figure 4 below.

14. Install display with universal interface to mount following the installation instructions provided with the mount.

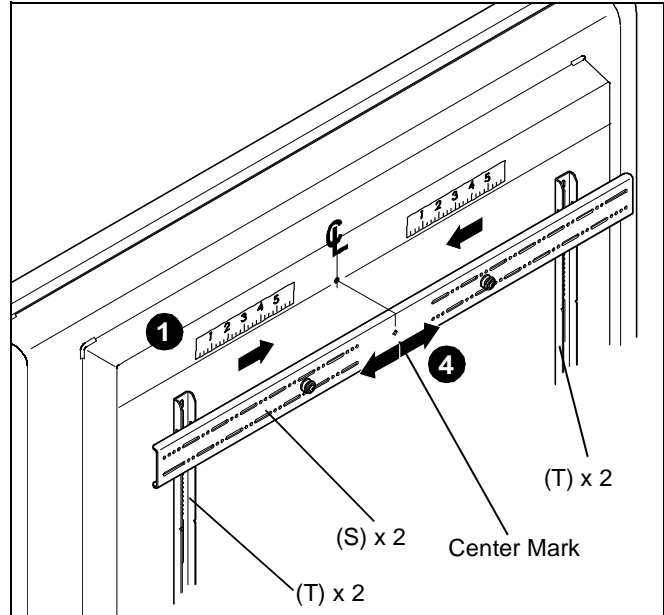

Figure 3

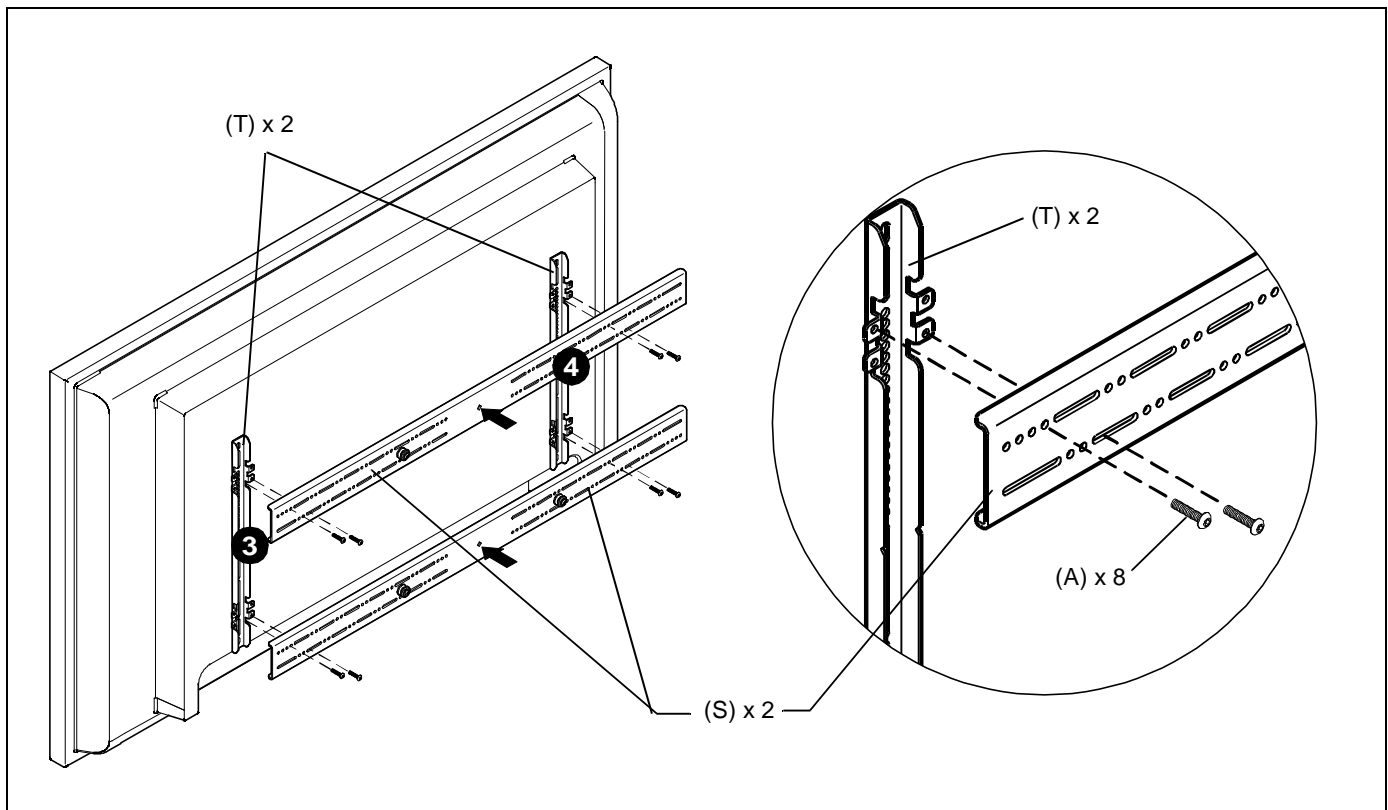

Figure 4



Our Mounts. Your Vision.

Chief Manufacturing, a products division
of Milestone AV Technologies

8805-000217 RevB

©2009 Milestone AV Technologies, a
Duchossois Group Company

www.chiefmfg.com

11/09

USA/International	A 8401 Eagle Creek Parkway, Savage, MN 55378
	P 800.582.6480 / 952.894.6280
	F 877.894.6918 / 952.894.6918
Europe	A Fellenoord 130 5611 ZB EINDHOVEN, The Netherlands
	P +31 (0)40 2668620
	F +31 (0)40 2668615
Asia Pacific	A Office No. 1 on 12/F, Shatin Galleria 18-24 Shan Mei Street Fotan, Shatin, Hong Kong
	P 852 2145 4099
	F 852 2145 4477

